

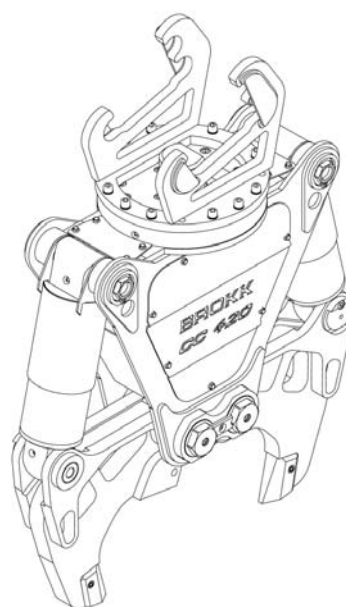

Catálogo de Implementos Brokk

El robot más versátil



Martillos hidráulicos



Modelo	Fuerza	Impactos minuto	Peso	Indicado para modelo Brokk
SB 52	101 J	960 - 2160	60 kg	Brokk 50
SB 102	252 J	840 - 1920	150 kg	Brokk 90, 180
SB 202	406 J	840 - 1800	230 kg	Brokk 180
SB 302	615 J	600 - 1380	345 kg	Brokk 260
SB 450	760 J	390 - 780	485 kg	Brokk 330D, 400
SB 552	1048 J	660 - 1140	535 kg	Brokk 400

Anguladores

Modelo	Ángulo	Indicado para modelo Brokk
PTA-O4,5	+ -79°	SB 152 / Brokk 90
PTA-O6	+ -79°	SB 152 / Brokk 180
PTA-O7	+ -79°	SB 202 / Brokk 260
PTA-O9	+ -70°	SB 302 / Brokk 400



Cizallas para hormigón



Modelo	Apertura	Diámetro corrugado	Fuerza de corte	Peso	Indicado para modelo Brokk
CC260	256 mm	-	22 t	73 kg	Brokk 50
CC320	320 mm	20 mm	35,6 t	140 kg	Brokk 90
CC420	420 mm	28 mm	33,6 t	270 kg	Brokk 180
CC520	531 mm	28 mm	48 t	407 kg	Brokk 260
CC560	551 mm	280 mm	52 t	590 kg	Brokk 330D, 400

Cizallas para acero

Modelo	Peso	Fuerza	Apertura	Indicado para modelo Brokk
SC270	385 kg	102 t	185 mm	Brokk 180, 260, 330D, 400
SC600	645 kg	138 t	245 mm	Brokk 180, 260, 330D, 400
HCS5	55 kg	17 t	300 mm	Brokk 50, 90
HCS7	123 kg	31 t	330 mm	Brokk 90, 180
CC420S	300 kg	74 t	145 mm	Brokk 180



Columnas de perforación



Modelo	Peso	Longitud	Carrera	Diámetro	Caudal	Indicado para modelo Brokk
Hidráulico	195 kg	1760 mm	600 mm	30-51 mm	0,4 m ³ / min / 5 bar	Brokk 90, 180
Neumático	290 kg	2776 mm	1800 mm	30-51 mm	6,0 m ³ / min / 6,5 bar	Brokk 90, 180, 330D, 400

Fresadoras

Modelo	Peso	Profundidad	Ancho	Indicado para modelo Brokk
PLB 300	290 kg	0-20 mm	300 mm	Brokk 180, 260, 330D
WS 15	200 kg	0-62 mm	557 mm	Brokk 180, 260, 330D, 400
WS 30	375 kg	0-89 mm	678 mm	Brokk 330D, 400
RT 15	82 kg	0-5 mm	203 mm	Brokk 50, 90



Pinzas abrazaderas



Modelo	Carga	Apertura	Peso	Indicado para modelo Brokk
G30	35 kg	300 mm	42 kg	Brokk 50
G50	80 kg	500 mm	140 kg	Brokk 90
G50	120 kg	500 mm	140 kg	Brokk 180
D02H	-	792 mm	140 kg	Brokk 90, 180
D03HPX-40	-	975 mm	310 kg	Brokk 260
D03HPX-50	-	1135 mm	375 kg	Brokk 400

Pinzas multiusos

Modelo	Peso	Volumen	Apertura	Ancho	Indicado para modelo Brokk
AO2H	140 kg	35 l	760 mm	300 mm	Brokk 90, 180
AO3H-40	265 kg	70 l	1474 mm	390 mm	Brokk 260
AO5H-40	320 kg	70 l	1474 mm	390 mm	Brokk 330D, 400



Bivalvas



Modelo	Peso	Volumen	Apertura	Ancho	Indicado para modelo Brokk
CO2H-25	110 kg	25 l	667 mm	250 mm	Brokk 90
CO3H-35	175 kg	65 l	879 mm	350 mm	Brokk 180
CO5H-40	210 kg	115 l	1090 mm	400 mm	Brokk 260
CO5HPX-40	340 kg	115 l	1250 mm	400 mm	Brokk 330D
CO5HPX-60	375 kg	170 l	1250 mm	600 mm	Brokk 400

Cazos



Volumen	Ancho	Peso	Indicado para modelo Brokk
20 l	330 mm	20 kg	Brokk 50
60 l	520 mm	61 kg	Brokk 90
80 l	690 mm	76 kg	Brokk 180
180 l	740 mm	153 kg	Brokk 260
250 l	960 mm	195 kg	Brokk 330D, 400

Otros implementos en el mercado

Los robots Brokk pueden trabajar con la mayoría de las herramientas del mercado. Cada modelo es compatible con un gran número de implementos para demolición, perforación, corte y manipulación. Consúltenos las características del implemento apropiadas para cada robot.



Brokk 50
Potencia 5,5 kW
Peso 470 kg
Peso máximo del implemento 70 kg



Brokk 90
Potencia 11 kW
Peso 980 kg
Peso máximo del implemento 140 kg



Brokk 180
Potencia 18,5 kW
Peso 1930 kg
Peso máximo del implemento 270 kg



Brokk 260
Potencia 22 kW
Peso 3050 kg
Peso máximo del implemento 395 kg



Brokk 330D (Diesel)
Potencia 30 kW
Peso 4400 kg
Peso máximo del implemento 550 kg



Brokk 400
Potencia 30 kW
Peso 4800 kg
Peso máximo del implemento 600 kg

